

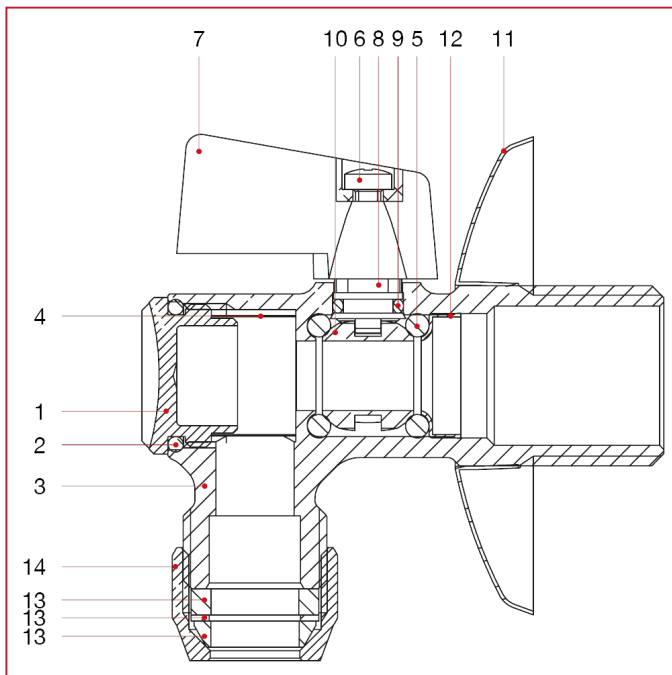

EINBAU- UND UNTERTISCHHÄHNE

906 Untertischkugelhahn mit Filter

WERKSTOFFE



NUM.	BESCHREIBUNG	Qt	MATERIALIEN
1	Kappe	1	Verchromtes Messing CW617N
2	O-Ring	1	NBR
3	Gehäuse	1	Verchromtes Messing CW617N
4	Schmutzfänger	1	Edelstahl AISI 304
5	O-Ring	2	NBR
6	Schraube	1	Verzinkter Stahl
7	Griff	1	Zamak
8	Spindel	1	Messing CW617N
9	O-Ring	1	NBR
10	Kugel	1	Verchromtes Messing CW617N
11	Rosette	1	Edelstahl AISI 430
12	Druckmutter	1	Messing CW508L
13	Olive 3 Stück	1	-
14	Mutter	1	Verchromtes Messing CW617N