

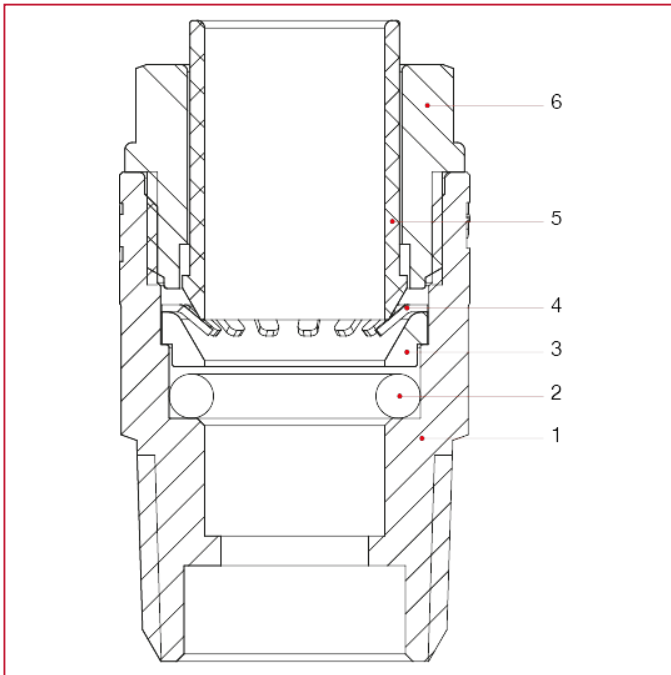

ITAP-FIT® ANSCHLÜSSE

615 Gerader Anschluss, Außengewinde

WERKSTOFFE



NUM.	BESCHREIBUNG	Qt	MATERIALIEN
1	Gehäuse	1	Messing CW625N
2	O-Ring	1	EPDM
3	Distanzstück	1	NIRETAN A EXL SC
4	Klemmring	1	Edelstahl AISI 301
5	Freigabehülse	1	GRIVORY GV-5H
6	Muffe	1	GRIVORY GV-5H