

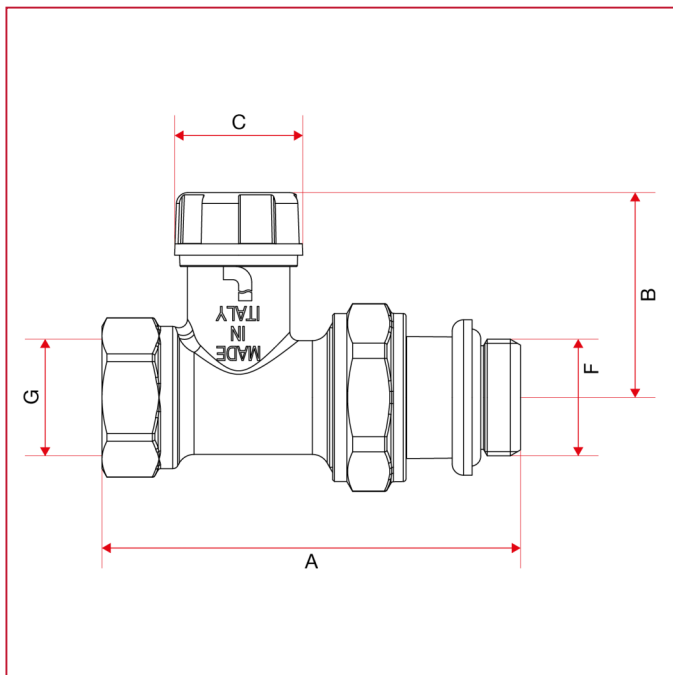

HANDVENTIL UND RÜCKLAUFVERSCHRAUBUNG

296S Gerade Rücklaufverschraubung

GESAMTABMESSUNGEN



| | 3/8" | 1/2" | 3/4" |
|------------------------|------|------|------|
| DN | 10 | 15 | 20 |
| A | 72 | 73,5 | 77,5 |
| B | 36 | 36 | 39 |
| C | 22,5 | 22,5 | 25 |
| F | 3/8" | 1/2" | 3/4" |
| G | 3/8" | 1/2" | 3/4" |
| Kg/cm ² bar | 10 | 10 | 10 |
| LBS - psi | 145 | 145 | 145 |