

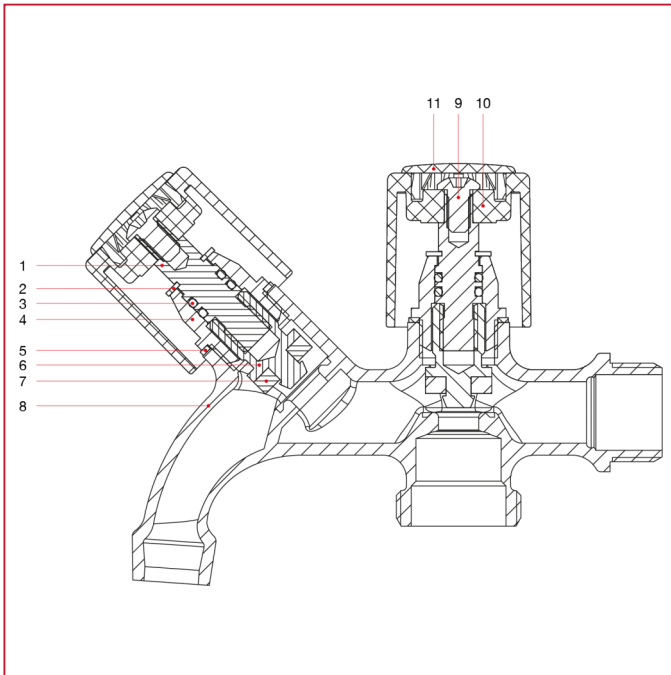

WASHING MACHINE VALVES

220 Washing machine valve

MATERIALS



| POS. | DESCRIPTION | N. | MATERIAL |
|------|-------------|----|----------------------------|
| 1 | Pin | 2 | Brass CW614N |
| 2 | Ring | 2 | Stainless steel AISI 302 |
| 3 | O-ring | 4 | NBR |
| 4 | Cap | 2 | Brass CW614N |
| 5 | Washer | 2 | Aluminium |
| 6 | Screw | 2 | Brass CW614N |
| 7 | Washer | 2 | NBR |
| 8 | Body | 1 | Chrome-plated brass CB753S |
| 9 | Screw | 2 | Zinc-plated steel C4C |
| 10 | Handle | 2 | Chrome-plated ABS |
| 11 | Clip | 2 | Varnished ABS |