

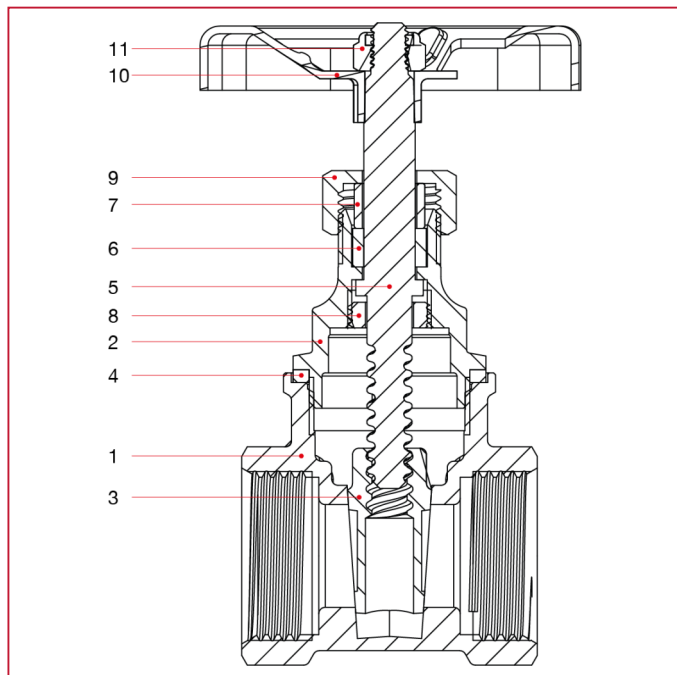

VANNES À OPERCULE

156 Vanne à opercule en laiton pn16

MATÉRIAUX tailles de 1/2" à 2"



POS.	DESCRIPTION	N.	MATÉRIAU
1	Corps	1	Laiton CW617N
2	Tête	1	Laiton CW617N
3	Disque	1	Laiton CW617N
4	Joint	1	NA1002
5	Tige	1	Laiton CW617N
6	Joint tige	1	FE1000
7	Presse-étoupe	1	Laiton CW617N
8	Bloque-tige	1	Laiton CW617N
9	Calotte	1	Laiton CW617N
10	Volant	1	Aluminium peint EN AB-46100
11	Écrou auto-bloquant	1	Acier galvanisé CL8



VANNES À OPERCULE

MATÉRIAUX tailles de 2"1/2 à 4"

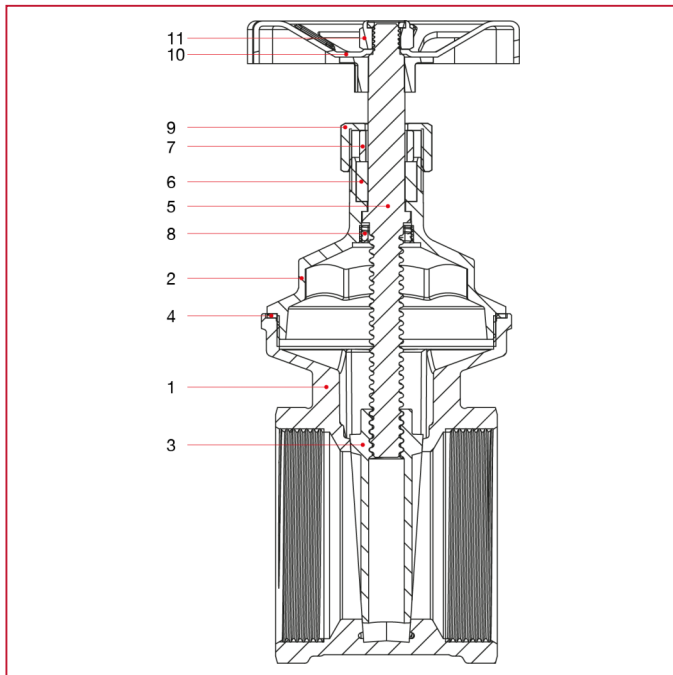

POS.	DESCRIPTION	N.	MATÉRIAU
1	Corps	1	Laiton CC754S
2	Tête	1	Laiton CW617N
3	Disque	1	Laiton CW617N
4	Joint	1	NA1002
5	Tige	1	Laiton CW617N
6	Joint tige	1	FE1000
7	Presse-étoupe	1	Laiton CW617N
8	Bloque-tige	1	Laiton CW617N
9	Calotte	1	Laiton CW617N
10	Volant	1	Aluminium peint EN AB-46100
11	Écrou auto-bloquant	1	Acier galvanisé CL8